

MTM500M TIMER CONFIGURATION

Staircase lights timer MTM500M allows the timed lighting of the staircase.

Operation: a short press of the button at the landing allows turning the light on for a pre-set time (default: 2 minutes). Whenever button is pressed again with the light on, the turning on time will be extended by the same duration.

Duration configuration: All configuration parameters are stored even in case of power supply failure. The turning on time is factory pre-set to the value of 2 minutes; it can be reconfigured from 2 seconds to 4 hours through quick presses (see below). To set the duration in seconds (from 2 seconds to 4 minutes), make 25 short presses of the button: (answer: 5 flashes). To go back to duration in minutes (from 2 minutes to 4 hours) make 26 short presses (answer: 6 flashes).

Extended Duration: This function proves useful when the staircase has to be cleaned. If one of the connected buttons is pressed for more than 3 seconds, light turns on for one hour (a quick flashing indicates that the control has been acknowledged and that the turning on duration has been set to one hour). Once the one hour time elapses, the module will resume standard operation. To advance light turning off before the one hour time elapses, press again one button for more than 3 seconds. To disable (or re-enable) the "extended duration" function. Make **29** short presses (answer: 9 flashes).

Warning: One minute before the turning on time elapses (30 seconds if the duration has been programmed in seconds), light will quickly flash and then start to slowly fade out; you can press a button before complete turning off, thus increasing the turning on time. To disable (or re-enable) the notification function, make **24** short presses (answer: 4 flashes).

Configuration lock: To disable configuration editing option, lock module by making **21** short presses (answer: 1 flash). Module can be unlocked at any time, making **23** presses (answer: 3 flashes).

WARNING

To use buttons with warning light with the Yokis modules, the use of the BV40 accessory is essential: one only, regardless of the number of connected buttons (max. 20).

WIRING OF A DIN RAIL MOUNTED TIMER WITH PUSHBUTTON WITH WARNING LIGHT WITH COMMON TO NEUTRAL

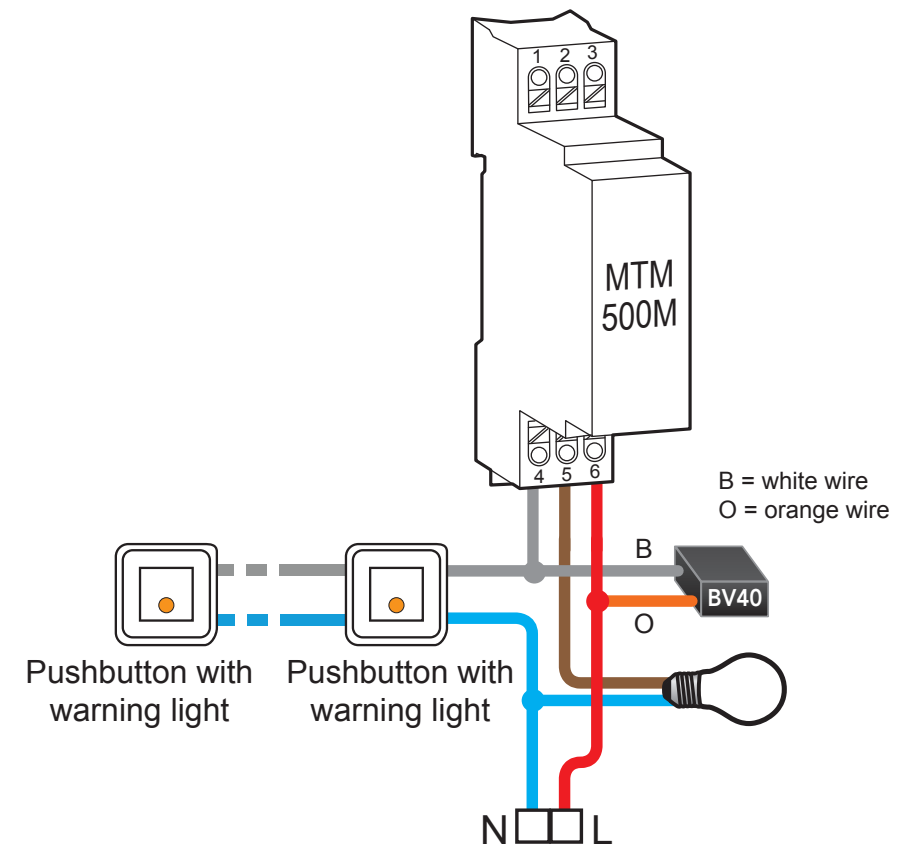

TECHNICAL INFORMATION

Model: MTM500M
 Min. power: 5 VA max.: 500 VA
 Current: 1.3 A, max. 2.2 A
 Dimensions: 1 DIN Rail Module